



WEIGH SCALE
W310 v2

PUBLISHED BY
Gallagher Group Limited
Kahikatea Drive, Private Bag 3026
Hamilton, New Zealand

www.gallagher.com
Copyright© Gallagher Group Limited 2015.
All rights reserved. Patents Pending.

Weigh Scale W310 v2 User Manual
3E2362 - Edition 3 - February 2015

DISCLAIMER: While every effort has been made to ensure accuracy, neither Gallagher Group Limited nor any employee of the company, shall be liable on any ground whatsoever to any party in respect of decisions or actions they may make as a result of using this information.

In accordance with the Gallagher policy of continuing development, design and specifications are subject to change without notice.

Developed and manufactured by Gallagher Group Limited, an ISO 9001:2000 Certified Supplier.

Table of Contents

Introduction	1
Care and maintenance	2
Installation	3
Installing the Weigh Scale bracket.....	3
Installing the loadbars	3
Installing the Weigh Scale.....	4
Power and batteries	5
The mode select switch	8
Setup	10
Selecting a setup option	11
Drafting	12
User options.....	14
Communications	15
Select a country	16
Before you begin weighing	17
About weighing	18
Weighing modes	18
About statistics	20
Draft statistics	20
Weight statistics.....	20
Deleting a weight from the statistics.....	21
Clearing the statistics.....	24
The weighing session	25
Weighing animals - automatic or manual modes.....	25
Weighing static loads - fine mode	27
At the end of the weighing session	27
Additional features	28
Zero tracking	28
Printing.....	29
Loadbar and platform options	31
Gallagher Standard Loadbars.....	31
Gallagher Heavy Duty Loadbars.....	31
Gallagher Super Heavy Duty Loadbars	32
Gallagher Suspension Load Cell 250 kg	33
Gallagher Suspension Load Cell 500 kg	33
Specifications	34
Weigh Scale W310 v2 Dimensions.....	34
General.....	34
Not for Trade	34
Weight increments	35
Waste Electrical and Electronic Equipment	36

INTRODUCTION

Thank you for purchasing the Gallagher Weigh Scale W310 v2 Weigh Scale. Gallagher Group Limited have been making agricultural weighing equipment for over 75 years and in that time have earned a reputation for quality equipment that withstands tough agricultural conditions.

The Gallagher Weigh Scale range of weighing systems is simple, tough, innovative and reliable.

All of the Weigh Scales in the Gallagher range can be matched to a choice of loadbar systems, as well as a range of platforms and crates to make an accurate and reliable weighing system.

Although designed specifically for agriculture, the Weigh Scale range is also suited to many industrial applications.

CARE AND MAINTENANCE

The Weigh Scale W310 v2 is a tough and reliable product designed for use in typical livestock environments. However, proper care and maintenance can extend its life.

Listed below are guidelines for keeping the Weigh Scale in good condition:

- Don't submerge the Weigh Scale in any liquid.
- Store the Weigh Scale in a cool, dry place. Avoid storing it in direct sunlight
- After use, clean the Weigh Scale with a damp cloth. Take care not to scratch the display.
- Fit the connector caps to keep the connections clean and dry.

INSTALLATION

Installing the Weigh Scale bracket

The bracket can be mounted on a flat vertical surface, or on a round post.

To mount the bracket on a flat vertical surface, for example a square post or board, use the outer holes.

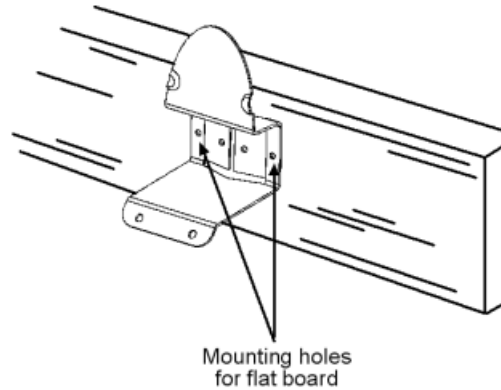

To mount the bracket on a round post, use the inner holes.

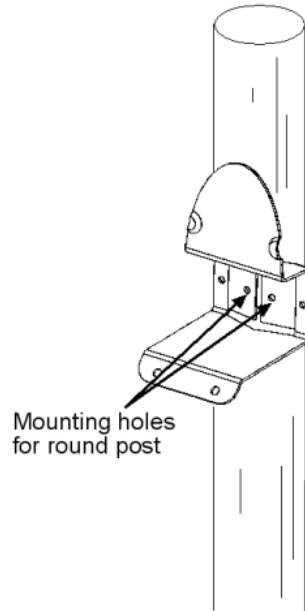

Don't mount the Weigh Scale bracket on the weighing crate or chute.

Installing the loadbars

To install the loadbars follow these steps.

1. Bolt the platform to the loadbars.
2. Ensure the platform is placed on a flat and level surface. Make sure it is not touching any rails or gates.
3. Either bolt the loadbars to the concrete pad or locate them on studs set into the concrete. This will prevent the platform from moving during the weighing session.

Installing the Weigh Scale

The Weigh Scale can be placed on a table top or mounted on the Weigh Scale bracket supplied.

Position the Weigh Scale:

- clear of the platform to ensure it does not interfere with the flow of animals during the weighing cycle
- within easy reach of the loadbar leads
- within easy reach of the operator (for manual weighing), and
- in a well-lit area

POWER AND BATTERIES

During a weighing session, the Weigh Scale can be powered by its internal battery alone or by its internal battery and either the battery charger or an external 12 volt battery.

The battery charger connects between an AC outlet and the Weigh Scale.

If either the battery charger or an external 12 volt battery is connected to the Weigh Scale, the Weigh Scale's internal battery will be charged while the Weigh Scale is in use.

For optimum performance, switch off the Weigh Scale and charge its internal battery for at least five hours. When fully charged, the internal battery on its own will power the Weigh Scale continuously for a minimum of eight hours.

Charging the battery

The battery in the Weigh Scale can be recharged using either a battery charger or an external 12 volt battery.

Recharging the battery will take up to five hours depending on the level of charge already in the battery. The Weigh Scale can be in use or can be switched off while the battery is being charged.

Using the battery charger

To charge the battery using the battery charger, follow these steps:

1. Connect the lead between the battery charger and the Weigh Scale.

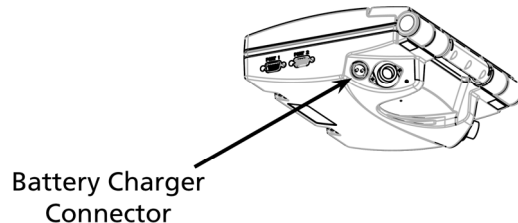

2. Plug the battery charger into an AC outlet and switch on.
3. Open the Weigh Scale case and make sure the battery charge icon  on the main screen is flashing. This indicates that the battery is charging and will be displayed whether the Weigh Scale is turned on or off.

Using an external 12 volt battery

To charge the Weigh Scale's internal battery using an external 12 volt battery, follow these steps:

1. Connect the supplied black and red battery leads to the Weigh Scale.
2. Connect the other end of the battery leads to the 12 volt battery.

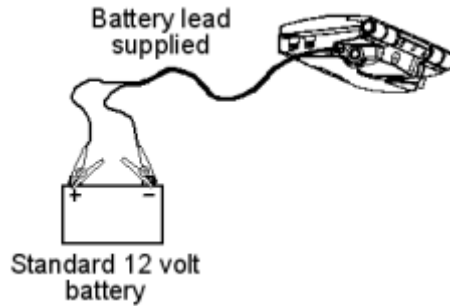

Connect the **Red** clip to the **Positive** terminal.



Connect the **Black** clip to the **Negative** terminal.

3. Open the Weigh Scale case and make sure the battery charge icon  on the main screen is flashing. This indicates that the battery is charging and will be displayed whether the Weigh Scale is turned on or off.

Battery charge status

The battery icon displays in the bottom left corner of the Weigh Scale's upper screen.

It is important to note that the battery icon will only ever show the actual amount of charge left in the battery when the Weigh Scale is turned on and disconnected from external power.

Fully Charged		Battery Icon bars are all displayed constantly.
Partially Charged		Battery Icon shows first four bars constantly.
Battery Flat		No Battery Icon bars are displayed.

When the Weigh Scale is connected to the external power supply the battery icon will display the charging status.

Charging		Battery Icon shows all the bars constantly filling and then disappearing.
----------	---	---

Low battery warning

When the charge remaining in the battery drops to a very low level, the battery charge icon on the Weigh Scale will start to flash and four beeps will sound every 30 seconds. After about 15 minutes, the Weigh Scale will shut down.



Low voltage shutdown

When the battery charge drops to a critical level, the Weigh Scale will shut down. At this stage it is necessary to recharge the battery.

THE MODE SELECT SWITCH

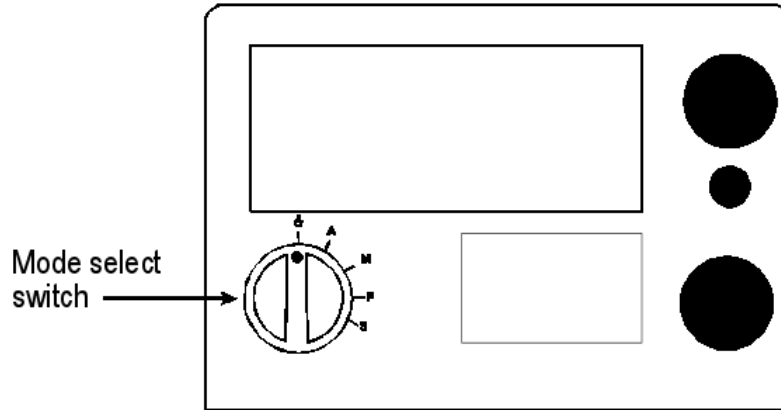
The Weigh Scale can operate in three weighing modes and a setup mode. The mode select switch is located on the left hand side of the Weigh Scale.



The mode select switch has five positions: , **A**, **M**, **F** and **S**. Immediately after you turn the switch to any position except , explanatory information will display on the lower of the two Weigh Scale screens. The explanatory information will display only for a few seconds; after it disappears, the screen displays information relevant to the selected option.

 This position turns the Weigh Scale off.

A This position selects automatic weighing. After the mode select switch is first turned to **A**, the following information briefly appears.

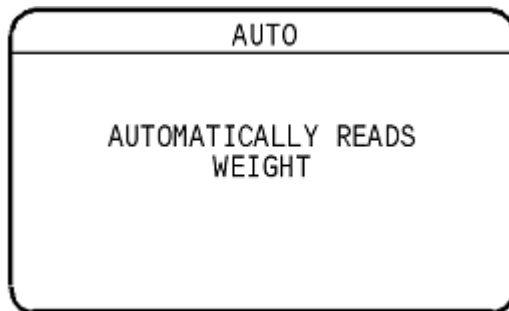

Automatic weighing is covered under *Weighing animals - automatic or manual modes* (p 25).

M This position selects manual weighing. After the mode select switch is first turned to **M**, the following information briefly appears.

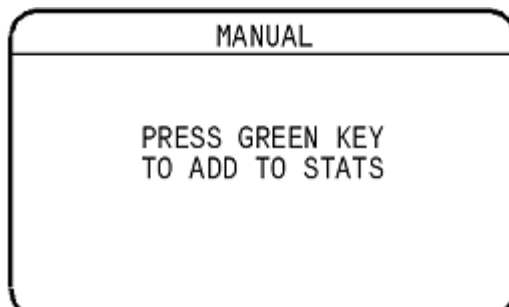

Manual weighing is covered under *Weighing animals - automatic or manual modes* (p 25).

- F** This position selects static load weighing. After the mode select switch is first turned to **F**, the following information briefly appears.

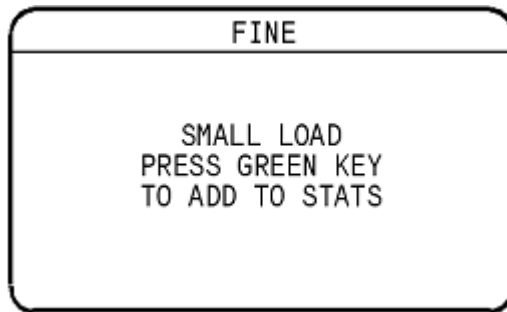

Manual weighing is covered under *Weighing static loads - fine mode* (p 27).

- S** This position accesses the setup options. After the mode select switch is first turned to **S**, the following information briefly appears.

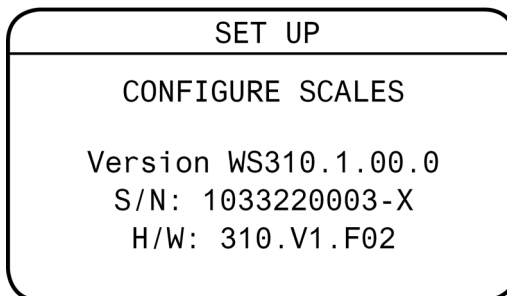

The software version used by the Weigh Scale, Serial Number and hardware version are also displayed. Setup options are covered under *Setup*.

Note:

The software version shown above may be different from that used in your Weigh Scale.

SETUP

The setup menu contains four options:

1. **DRAFT MENU** - turns Drafting on or off.
2. **USER OPTIONS** - selects a unit of weight measurement and enables live printing.
3. **COMMUNICATIONS** - sets up a connection to a device plugged into the Weigh Scale's communications port.
4. **SELECT COUNTRY** - for a specific country, sets a language, country-specific terminology and other option defaults.

To access the setup menu, turn the mode select switch to **S**.

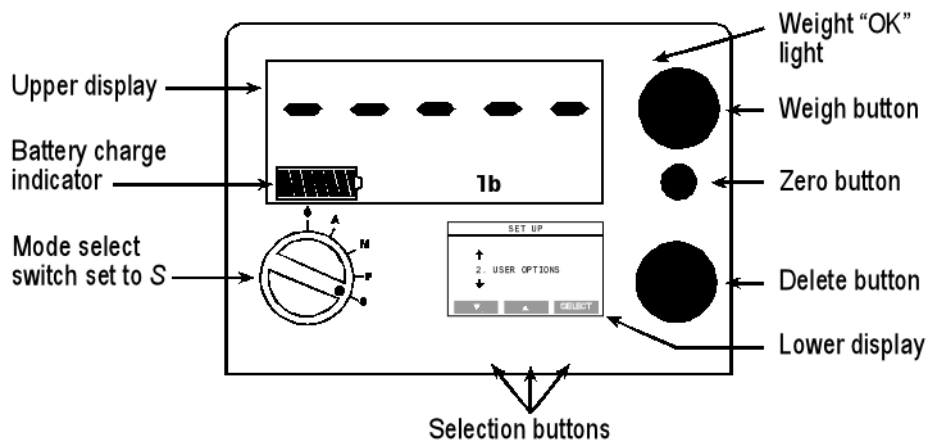

The setup menu displays on the lower of the two Weigh Scale screens. Press the buttons directly below this screen to select menu options.

Selecting a setup option

When you turn the mode select switch to **S**, one of the setup menu options described on the previous page will display.

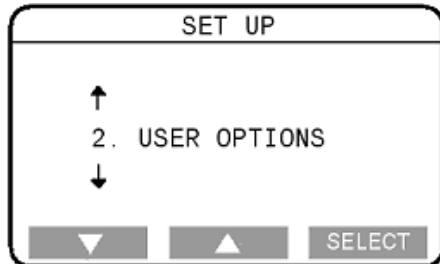



The setup menu items are numbered from 1 to 4.

Press the  button to move to the previous setup menu item.

Press the  button to move to the next setup menu item.

For example, to move from 2. USER OPTIONS to 3. COMMUNICATIONS press .

To move from 3. COMMUNICATIONS to 2. USER OPTIONS press .

Press  to select the currently displayed item.

For more information about each of the setup menu items, refer to the following sections.

Drafting

The Draft Menu option lets you turn Drafting on or off and set a drafting limit.

Turning Drafting on or off

To turn Drafting on or off, follow these steps.

1. Select **1. DRAFT MENU** from the setup menu.
2. Depending on how the Weigh Scale was previously set up, either the Drafting Off or the Two Way Drafting screen will display.

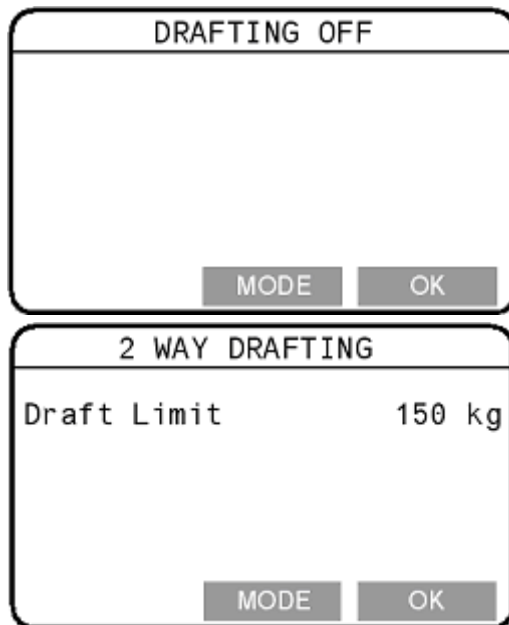

3. Depending on the screen displayed, do one of the following.
 - If the Drafting Off screen appears and you want to turn Drafting on, press **MODE**, then press **OK** twice.
 - If the Two Way Drafting screen appears and you want to turn Drafting off, press **MODE**, then press **OK**.
4. After you press the **OK** button the final time, you will be returned to the setup menu.

Changing the drafting limit

To change the drafting limit, follow these steps.

1. Select **1. DRAFT MENU** from the setup menu.
2. If the Drafting Off screen displays, press the **MODE** button.
3. The current drafting limit will display on a screen that looks similar to that below.

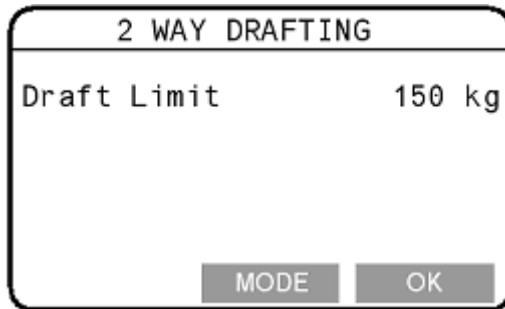

4. Press the **OK** button to enter the edit mode. The screen will change to look like that below.

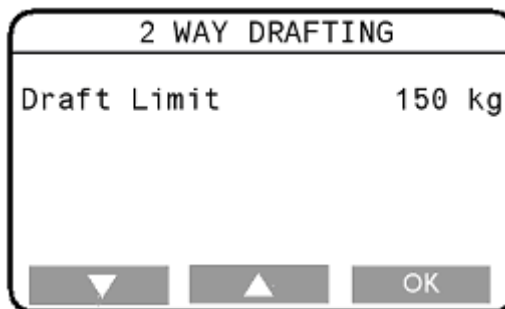

5. Press the **▲** or **▼** buttons repeatedly to change the drafting limit one step at a time. If you press and hold down either button, the limit will change rapidly.
6. Press **OK** to save the currently-displayed drafting limit and return to the setup menu.



User options

The User Options screen lets you select the unit of measurement that you want to use when weighing animals. You can also turn live printing on or off.

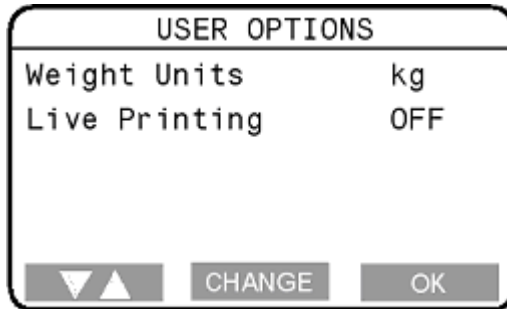
To display the User Options screen, select **2. USER OPTIONS** from the setup menu.



Changing a user option

Press the  button to select the option you want to edit, then press .

Refer to the sections below for more information on each of the User Options.

Press  to save the displayed user options and return to the setup menu.

Weight units

You can specify whether the Weigh Scale uses kilograms (kg) or pounds (lb).

Live printing

When Live Printing is turned on, the Weigh Scale will print the measurement it makes each time it captures a weight. Refer to *Printing* (p 29) for more information.

Live Printing will only occur if you have connected the Weigh Scale printer to the Weigh Scale and set the port to Printer as described in *Communications* (p 15).

Note:

This feature will not work with a standard PC printer.

Communications

You can connect a printer to the Weigh Scale. Optionally, if you have selected the NZ/AU country option, you can connect the Weigh Scale to a device that can respond to Weigh Scale protocols.

Connections are made to the port located on the upper left hand side edge of the Weigh Scale.

If you attach a device to the port, you must configure the port to suit. You do this from the Communications screen.

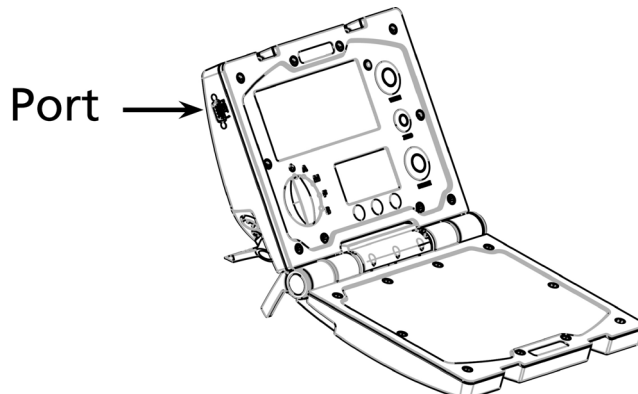

To display the Communications screen, select **3. COMMUNICATIONS** from the setup menu.

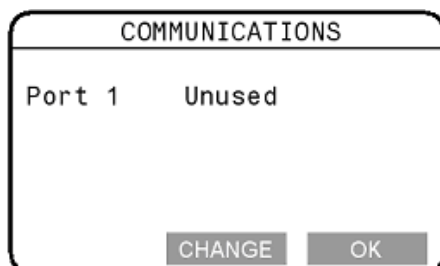

To change the port setting, follow these steps.

1. Press the **CHANGE** button repeatedly until the required option is selected.
2. Press **OK** to save the setting and return to the setup menu.

Options are:

- | | |
|------------------|---|
| Unused | The port is unused. This is the default option. |
| Printer | The port is connected to a Weigh Scale printer. This option prints weights and statistics during a session. |
| Ruddweigh | (This option will only appear when your country selection is NZ/AU . See <i>Select country</i> (p 16).)
The port is connected to a device that can respond to Weigh Scale protocols. When this option is enabled, the port transmits weight information continuously. |



Select a country

From the Select Country screen you choose the country in which the Weigh Scale will be used. Selecting a country changes the language and sets some country-specific terminology and options.

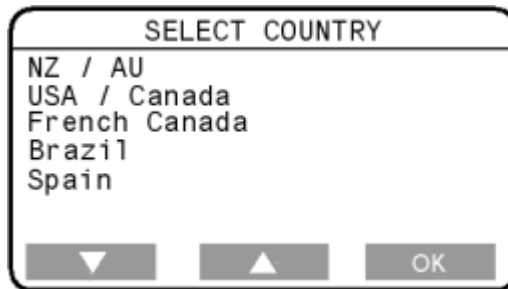
To display the Select Country screen choose **SELECT COUNTRY** from the setup menu.



To change the country, follow these steps.

1. Press the  or  button to select the desired country.
2. Press .

BEFORE YOU BEGIN WEIGHING

1. Release the catches on the front of the Weigh Scale and open the case.
2. Place the Weigh Scale on a flat surface or clip it onto the Weigh Scale bracket.

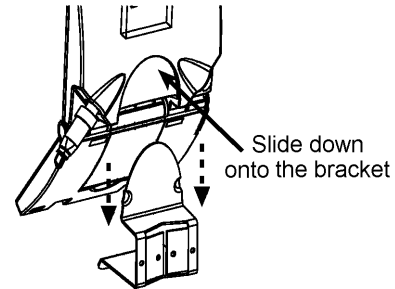
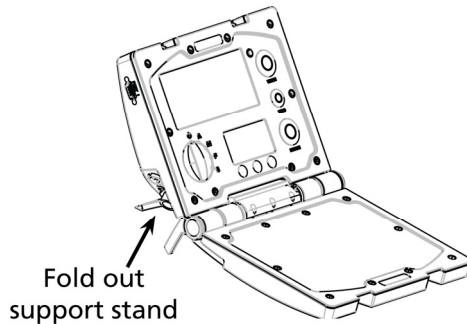

3. Connect the leads from both loadbars to the Weigh Scale.
4. If required, connect to an AC outlet via the battery charger or connect to a 12 volt battery. If you are not connecting to an external power source, the Weigh Scale's internal battery should be fully charged. Refer to *Charging the battery* (p 5).
5. To change or check the setup options, turn the mode select switch **S** to display the setup menu.

You can use the setup menu to:

- turn on Drafting, if you require it, and set the drafting limit.
- set up a connection to a Weigh Scale printer.

Refer to *Setup* (p 10), if you need more information.

You are now ready to start a weighing session.

ABOUT WEIGHING

The Weigh Scale has three weighing modes: Automatic, Manual and Fine.

The Automatic and Manual weighing modes are optimised for weighing live animals. The Fine mode is optimised for weighing static objects.

Weighing modes

Automatic

Automatic mode is recommended for yards that allow a smooth flow of animals across the weighing platform.

In Automatic mode, the Weigh Scale automatically starts the weight measurement process as soon as the animal steps onto the platform. After the weight has been captured, the Weigh Scale beeps and displays the captured weight. The captured weight continues to display until the next animal steps onto the platform.

After the animal leaves the platform, the Weigh Scale attempts to compensate for the weight of any accumulation of mud or dung left on the platform. If it succeeds, the Weigh Scale displays a zero icon. If it does not you can manually restore zero by pressing the blue zero button.

Manual

Manual mode is recommended for yards that do not allow a smooth flow of animals across the weighing platform or where the animals are restless. This mode allows the operator to decide when the measurement is made.

In manual mode, the operator presses the green weigh button to start the weight measurement process. After the weight has been captured, the Weigh Scale beeps and displays the captured weight. The captured weight continues to display until the next animal steps onto the platform.

After the animal leaves the platform, the Weigh Scale attempts to compensate for the weight of any accumulation of mud or dung left on the platform. If it succeeds, the Weigh Scale displays a zero icon. If it does not you can manually restore zero by pressing the blue zero button.

Fine

Fine mode is recommended for weighing static loads such as fleeces or produce.

In Fine mode, the Weigh Scale displays the weight on the platform in the same way as a bathroom scale.

If a weight measurement is to be added to the session statistics, the operator presses the green weigh button. The weight is captured at this point, but it is not stored in the weight record until the weight is removed from the platform. After the weight has been captured, the statistics are updated. For information about statistics, see *Session statistics*. The displayed weight continues to reflect the actual weight on the platform.

In Fine mode, automatic zero tracking is switched off. This means the Weigh Scale does not automatically compensate for the weight of objects left on the platform after the load has been removed. For more information, see *Zero tracking* (p 28).

The blue zero button has a function in Fine mode if you want to make net-weight measurements of a load inside a container. For example, you could place an empty container on the weighing platform and press the blue zero button. If you then filled the container, the weight indication will be only that of the container's contents.

Note: In Fine mode, after the blue zero button has been pressed, the weight indication shows zero but the **ZERO** icon does not display.

ABOUT STATISTICS

When the Weigh Scale is in the Automatic, Manual or Fine weighing mode, the lower screen displays statistics of the current weighing session. The way statistics are displayed depends on whether Drafting is turned on or off.

Draft statistics

If Drafting is turned on and you are using Automatic or Manual weighing modes, the Drafting Stats screen will display information similar to that shown below.

DRAFT STATS [kg]		
Limit	300	
	Low	High
Number	6	8
Average	292	314
Total	1753	2508
CLEAR		

In the example above, the drafting limit was set to 300 kg. Six animals weighed below 300 kg. These had an average weight of 292 kg and a total weight of 1753 kg. Eight animals weighed 300 kg or more. These had an average weight of 314 kg and a total weight of 2508 kg.

Weight statistics

If Drafting is turned off or you are weighing in Fine mode, the screen will display information similar to that shown below.

WEIGHT STATS [1b]	
Number	21
Average	286
Total	6006
Lowest	257
Highest	341
CLEAR	

In the example above, 21 animals or objects were weighed. The average weight was 286 , the total weight was 6006 , the lowest measurement was 257 and the highest measurement was 341 .

Deleting a weight from the statistics

In the Automatic weighing mode, statistics are updated each time the Weigh Scale captures a weight. In the Manual or Fine modes, a weight is captured and the statistics updated only if the operator presses the green button.

You can delete a captured weight from the statistics at two stages during a weighing session ;

- while the animal or static load is still supported by the platform; or
- immediately after the animal has stepped off the platform or the static load has been removed from the platform.

If you delete a weight from the statistics while the animal or static load is still supported by the platform, you can also re-weigh by pressing the green weigh button.

Animals

Delete the weight just after the animal has left the platform

This feature is available when the Weigh Scale is set to either the Automatic or Manual mode.

After the weighed animal has left the platform and before the next animal steps onto the platform, you have an opportunity to delete from the statistics the weight just captured.

To delete the weight, press the red delete button.

The last captured weight will be removed from the statistics and the lower screen will briefly display the following message.

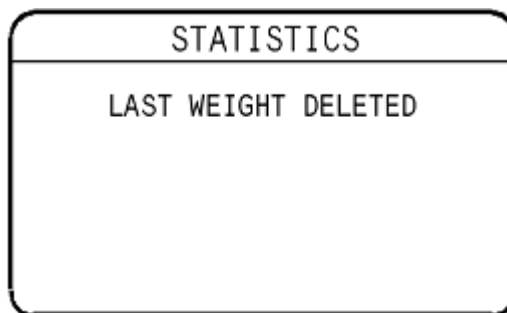

Note:

You can only delete the last weight captured from the statistics. Weights captured prior to the last cannot be removed by pressing the delete button again.

Static loads

Delete the weight after the load has been removed from the platform

This feature is available when the Weigh Scale is set to the Fine mode.

After the static load has been removed from the platform and before another load is placed on the platform, you have an opportunity to delete from the statistics the weight just captured.

To delete the weight, press the red delete button.

The last captured weight will be removed from the statistics and the lower screen will briefly display the following message.

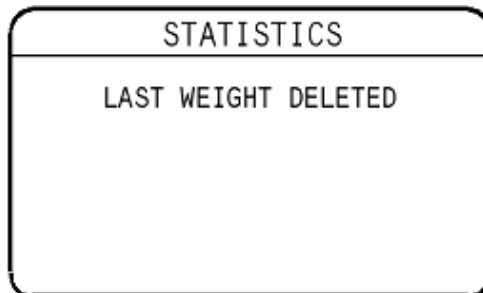

Note:

You can only delete the last weight captured from the statistics. Weights captured prior to the last cannot be removed by pressing the delete button again.

Clearing the statistics

If you want to clear the statistics, follow these steps.

1. Set the mode select switch to the Automatic, Manual or Fine weighing mode.
2. Press the **CLEAR** button.

After you press the **CLEAR** button, all values will be set to zero and the lower screen will display as shown in the relevant illustration below.

WEIGHT STATS [1b]	
Number	0
Average	0
Total	0
Lowest	0
Highest	0
CLEAR	

DRAFT STATS [kg]		
Limit	300	
	Low	High
Number	6	8
Average	292	314
Total	1753	2508
CLEAR		

Note: Once the statistics have been cleared from the Weigh Scale they cannot be recovered.

THE WEIGHING SESSION

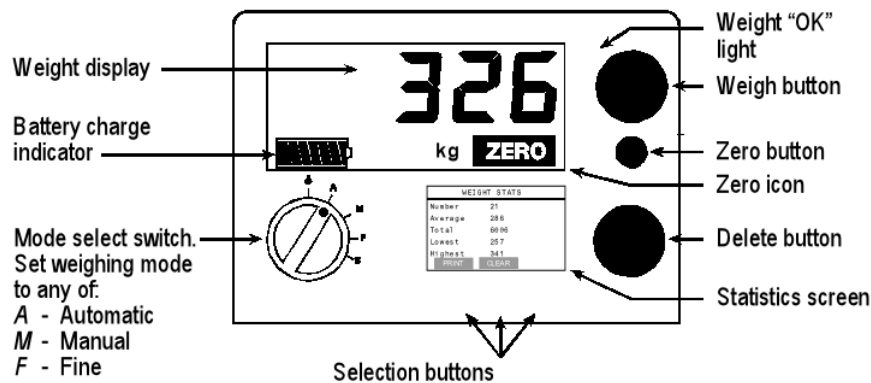

Weighing animals - automatic or manual modes

At all times during the weighing session, ensure that the underside of the platform is kept free of dirt and stones.

1. Select the weighing mode that you want to use by turning the mode select switch to **A** (Automatic), or **M** (Manual).

2. If you want to reset the statistics display to zero, press the **CLEAR** button.

For more information refer to *Clearing the statistics* (p 24).

3. The Weigh Scale attempts to compensate for the weight of any accumulation of mud or dung left on the platform. If it is successful, the **ZERO** icon displays. If the icon does not display, press the blue Zero button.
4. Load the animal onto the platform. Ensure the animal is entirely supported by the platform — no hooves on the ground — and that no object is restraining or resting on the animal.
5. The Weigh Scale captures the weight in a way that depends on the weighing mode selected.
 - **Automatic Mode** After the animal has become calm, the Weigh Scale automatically captures the weight. The time taken to capture the weight depends on the movement of the animal.
 - **Manual Mode** Press the green weigh button. After the animal has become calm, the Weigh Scale captures the weight. The time taken to capture the weight varies depending on the movement of the animal.
6. Once the Weigh Scale locks onto the weight, the following events occur.
 - The Weigh Scale beeps.
 - The weight measurement displays in the upper screen.
 - The red light glows.
 - The **OK** icon displays in the upper screen.

If Drafting is turned on, the upper screen displays H (High) or L (Low), indicating the drafting category into which the measurement falls.

7. If the weight has locked on, but you want to re-weigh the animal, press the green **Weigh** button. The Weigh Scale re-weighs the animal and locks the weight again. The new weight replaces the original weight and the statistics are updated.
8. Record the weight.
9. Move the animal off the platform. After the animal has left the platform, the following events occur.
 - The red light goes out.
 - The **OK** icon disappears from the upper screen.
 - The statistics screen updates.

The weight measurement continues to display in the upper screen until the next animal steps onto the platform.

10. If you want to delete the weight just captured, follow the procedure set out under *Delete the weight just after the animal has left the platform* (p 22).

Weighing static loads - fine mode

1. Turn the mode select switch to **F** (Fine mode).
2. If you want to reset the statistics display to zero, press the  button.

For more information refer to *Clearing the statistics* (p 24).

3. Check that the weight displayed is zero. If it is not, check that no unwanted objects are resting on the weighing platform, then press the blue zero button.

Note:

The  icon does not display in Fine mode.

4. Place the load onto the platform.
5. Record the weight.
6. Press the green weigh button if you want to add the weight to the statistics.
7. If the weight has locked on, but you want to re-weigh the load, press the green **Weigh** button. The Weigh Scale re-weighs the load and locks the weight again. The new weight replaces the original weight and the statistics are updated.

Weight-on-scale memory

The Weigh Scale remembers the weight on the display at the time it is switched off. This weight is restored if the same weight is on the platform at the time the Weigh Scale is switched back on.

For example, if you are using Fine mode to weigh wool in a bale on a wool press, you can part-fill the bale and then turn the Weigh Scale off at the end of the day. Provided the load is still on the Weigh Scale, this weight is remembered when you return the following day and switch the Weigh Scale back on. As you add to the bale, the weight increases, from the remembered weight at the end of the previous day.

At the end of the weighing session

1. Switch the Weigh Scale off by turning the mode select switch to the  position.
2. Disconnect the loadbar cables.
3. Fit the protective caps to the loadbar cables.
4. Fit the protective caps to the Weigh Scale.

ADDITIONAL FEATURES

Zero tracking

As animals pass through the weighing crate, an accumulation of mud and dung may build up on the weighing platform. The Weigh Scale can compensate for the weight of this accumulation by subtracting it from the total weight. The automatic subtraction of the residual weight from the total weight is called zero tracking.

Zero tracking ensures that the Weigh Scale captures the animal's weight and not the mess left on the platform.

The way zero tracking is initiated depends on the weighing mode.

Automatic and Manual modes

In the Automatic and Manual weighing modes, zero tracking is automatically implemented if, after the animal leaves the weighing platform, the residual weight is within a defined zero tracking range.

- If the residual weight is within the defined range, the **ZERO** icon displays.
- If the residual weight is outside the defined range, the icon does not display.

To manually compensate for the residue, press the blue zero button. The **ZERO** icon displays.

During a weighing session, if the Weigh Scale consistently does not restore to zero, check that there are no obstructions under or around the platform or crate.

Fine mode

In the Fine weighing mode, automatic zero tracking is disabled.

The **ZERO** icon does not display in the Fine weighing mode.

Printing

A Weigh Scale printer can be attached to the Weigh Scale W310 v2. If the Weigh Scale printer is connected during a weighing session, you can configure the Weigh Scale to print each animal's weight automatically. You can also print the statistics at any time during or after the session.

The Weigh Scale printer has its own internal rechargeable battery. The battery can be recharged using the battery charger supplied with the printer.

Note:

You can only use a Weigh Scale printer with the Weigh Scale W310 v2 scale.

Printing weights during a weighing session

To print each weight during a weighing session, follow these steps.

1. Connect the printer cable to the port on the Weigh Scale.
2. Turn the mode select switch to **S** to display the SET UP menu.
3. Select **COMMUNICATIONS**.
4. Ensure the port is set to **Printer**.
5. Press **OK** to return to the SET UP menu.
6. Select **USER OPTION** and set **Live Printing** to **ON**.
7. Press **OK** to return to the SET UP menu.
8. Select the required weighing mode by turning the mode select switch to **A** (Automatic), **M** (Manual) or **F** (Fine).
9. Each time the Weigh Scale captures a weight it will be printed. If Drafting is turned on, the drafting category (H-high or L-low) will be printed beside each weight.

Printing statistics during a weighing session

To print statistics during a weighing session, follow these steps.

1. Connect the printer cable to the port on the Weigh Scale.
2. Turn the mode select switch to **S** to display the setup menu.
3. Select **3. COMMUNICATIONS**.
4. Ensure the port is set to **Printer**.
5. Press **OK** to return to the setup menu.
6. Select the required weighing mode by turning the mode select switch to **A** (Automatic), **M** (Manual) or **F** (Fine).
7. Press the **PRINT** button on the Weight Stats or Drafting Stats screen.

The statistics on the Weight Stats or Drafting Stats screen will be printed.

WEIGHT STATS [kg]	
Number	21
Average	572
Total	12012
Lowest	541
Highest	682
PRINT	CLEAR

LOADBAR AND PLATFORM OPTIONS

It is recommended that you use Gallagher Loadbars with the Weigh Scale W310 v2.

The Weigh Scale W310 v2 Scale recognises most commonly available Loadbar sets. To connect to some Loadbar sets, adapter cables may be required.

If you are not using Gallagher Loadbars, a calibration check will be required prior to first use.

Gallagher Standard Loadbars

Features

- 2000 kg weighing capacity - Available in 600mm (23") and 1000mm (39") lengths
- Tough rugged steel loadbars
- Bottom feet mounting holes extend beyond top covers for ease of bolting down
- Slotted top mounting holes fit all sizes of platforms and crushes
- 6m (20') long tough loadbar cables fitted with high quality connectors
- Fully waterproof
- No rubber mounts

Talk to your Gallagher dealer about the best platform and/or crate for your requirements.

Gallagher Heavy Duty Loadbars

Features

- 3500 kg weighing capacity
- 1000 mm (39") rugged steel loadbars
- Bottom feet mounting holes extend beyond top covers for ease of bolting down
- 6 m (20') long tough loadbar cables fitted with high quality connectors
- Fully waterproof
- No rubber mounts
- High capacity load cells withstand large shock loads
- Heavy steel chassis construction absorbs the harshest of impacts
- Set them and forget them for permanent installation under large crushes.

Talk to your Gallagher dealer about the best platform and/or crate for your requirements.

Gallagher Super Heavy Duty Loadbars

Features

- 4500 kg weighing capacity
- 1000 mm (39") rugged steel loadbars
- Bottom feet mounting holes extend beyond top covers for ease of bolting down
- 6 m (20') long tough loadbar cables fitted with high quality connectors
- Fully waterproof
- No rubber mounts
- High capacity load cells withstand large shock loads
- Heavy steel chassis construction absorbs the harshest of impacts
- Set them and forget them for permanent installation under the largest crushes

Talk to your Gallagher dealer about the best platform and/or crate for your requirements.

Gallagher Suspension Load Cell 250 kg

Features:

- 250 kg capacity loadcells
- Replaces mechanical scale for hanging crates
- Compact sturdy design
- No rubber to delaminate or rot
- Spiral spring metal reinforced cable
- High quality moisture proof connectors

Gallagher Suspension Load Cell 500 kg

Features:

- 500 kg capacity loadcells
- Replaces mechanical scale for hanging crates
- Compact sturdy design
- No rubber to delaminate or rot
- Spiral spring metal reinforced cable
- High quality moisture proof connectors

SPECIFICATIONS

Weigh Scale W310 v2 Dimensions

	Metric	Imperial
Length	232 mm	9.25"
Width	212 mm	8.5"
Height	90 mm	3.5"
Weight	2 kg	4.4 lb

General

Operating Temperature	-20° to 50° C -5° to 120° F
Accuracy	± 1%
Environmental Protection Rating	IP65
Input Voltage	11 - 14 VDC

Not for Trade

This Weigh Scale is not certified "Legal for Trade".

Weight increments

For Gallagher Loadbar sets, the weight increments are preset as shown in the table. For other loadbar sets talk to your Gallagher dealer.

Weight Range	Gallagher Standard Loadbars (2000 kg)	Gallagher Heavy Duty Loadbars (3500 kg) and Gallagher Super Heavy Duty Loadbars (4500 kg)
---------------------	--	--

Automatic or Manual modes:

0 - 49.9 kg	200 g increments	500 g increments
50 - 199.9 kg	500 g increments	500 g increments
200 - 499.9 kg	1 kg increments	1 kg increments
500 - 1999.9 kg	2 kg increments	2 kg increments
2000 - 4999.9 kg	Not Applicable	5 kg increments

Fine mode:

0 - 49.9 kg	100 g increments	200 g increments
50 - 199.9 kg	500 g increments	500 g increments
200 - 499.9 kg	1 kg increments	1 kg increments
500 - 1999.9 kg	2 kg increments	2 kg increments
2000 - 4999.9 kg	Not Applicable	5 kg increments

WASTE ELECTRICAL AND ELECTRONIC EQUIPMENT



This symbol on the product or its packaging indicates that this product must not be disposed of with other waste. Instead, it is your responsibility to dispose of your waste equipment by handing it over to a designated collection point for the recycling of waste electrical and electronic equipment. The separate collection and recycling of your waste equipment at the time of disposal will help conserve natural resources and ensure that it is recycled in a manner that protects human health and the environment. For more information about where you can drop off your waste equipment for recycling, please contact your local city recycling office or the dealer from whom you purchased the product.